

---

# The Sustainability of Packaging Systems for Fruit and Vegetable Transport in Europe based on Life-Cycle-Analysis

---

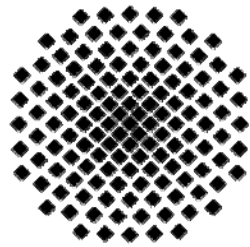

**Universität Stuttgart**

Lehrstuhl für Bauphysik

---



Life Cycle Engineering

---

# The Sustainability of Packaging Systems for Fruit and Vegetable Transport in Europe based on Life-Cycle-Analysis

---

InLCA/LCM, Portland, October 2<sup>nd</sup> to 4<sup>th</sup>, 2007

Stefan Albrecht, Dept. LCE (GaBi), University of Stuttgart

Leif-Patrik Barthel, Dept. LCE (GaBi), University of Stuttgart

Martin Baitz, PE International GmbH

Sabine Deimling, PE International GmbH

Matthias Fischer, Dept. LCE (GaBi), University of Stuttgart

Julia Pflieger, Dept. LCE (GaBi), University of Stuttgart

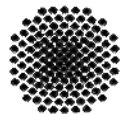

**Universität Stuttgart**

Lehrstuhl für Bauphysik

Life Cycle Engineering



# Content

- ▶ Goal and scope of the study
- ▶ Life cycle model and system boundaries
- ▶ Selected results
- ▶ Conclusions

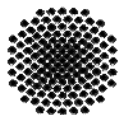

---

## Goal and scope of the study

### Goal of the project:

- Life Cycle Assessment (LCA) study to analyze and compare the common transport packaging systems for fruit and vegetables in Europe with respect to the environmental impacts related to their use
- Knowledge to be gained on costs and selected social aspects within the same system boundaries (Results presented on 9<sup>th</sup> February, 2007 in Berlin – Germany)

### Partners of the project:

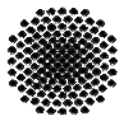

# Goal and Scope

## Regarded transport packaging systems

Wooden boxes  
(One way)



Foldable plastic crates  
(Multi way)

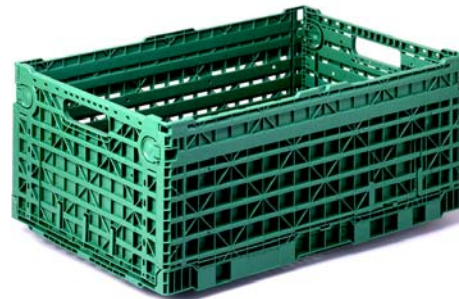

Cardboard boxes  
(One way)

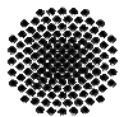

# Goal and Scope

## Regarded transport packaging systems

	Wooden boxes	Plastic crates	Cardboard boxes
Production	Wood	Polypropylene Polyethylene	Cardboard
Transport	One way	Multi way	One way
End of Life	Energy recovery material recycling	Energy recovery material recycling	Energy recovery material recycling
Weight of boxes [kg]	0,9	2	0,785
Dimension exterior [mm]	600x400x240	600x400x240	600x400x240
Producer countries (Fruit & Vegetable)	Spain, Italy, France, The Netherlands, Germany		
Consumer countries (Fruit & Vegetable)	France, The Netherlands, Germany, Great Britain		

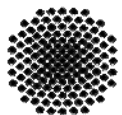

---

# Goal and scope

## Functional Unit

### The functional unit

Is the distribution of 1.000 tons of fruit/vegetables either transported in wooden boxes, cardboard boxes (both one-way systems) or in plastic crates (multi way system).

### The extended functional unit

Is the distribution of 3.333.350 filled boxes/crates, each with 15 kg of fruit/vegetables, either transported in wooden boxes, cardboard boxes (both one-way systems) or in plastic crates (multi way system).

= 1.000 tons distributed \* 50 rotations (in 10 years lifetime for multi way system)

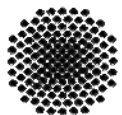

---

# Goal and scope

## The two regarded scenarios

### Conservative scenario

- ▶ 10 years lifetime of plastic crates
- ▶ 50 rotations of plastic crates
  - »  $66,667 * 50 = 3,333,350$  fillings

### Technical scenario

- ▶ 20 years lifetime
- ▶ 100 rotations
  - »  $66,667 * 100 = 6,666,700$  fillings

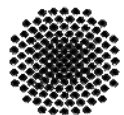

# Life Cycle Model

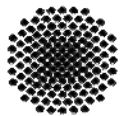
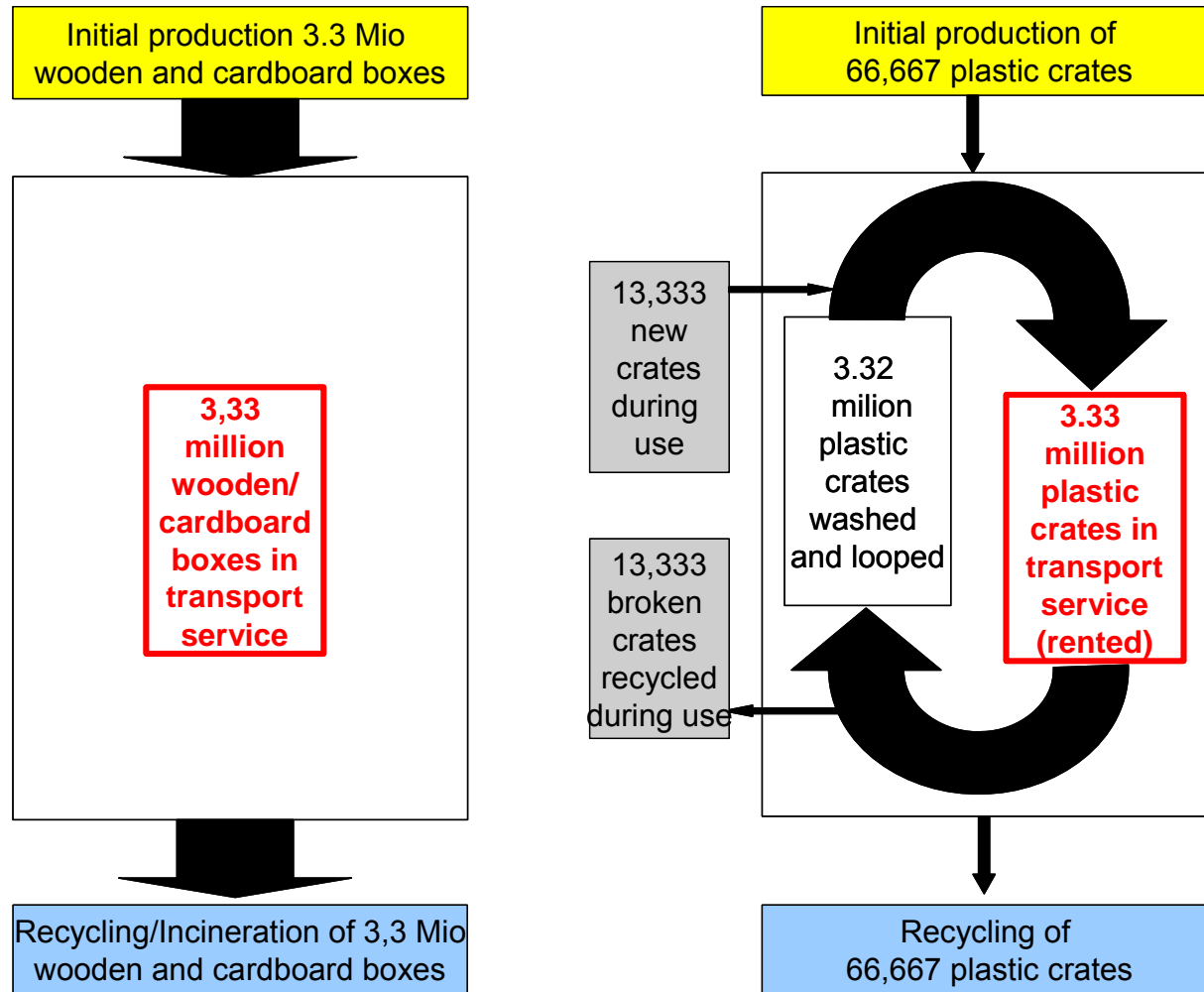

# Life Cycle Model – routes of transportation

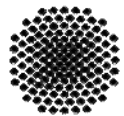
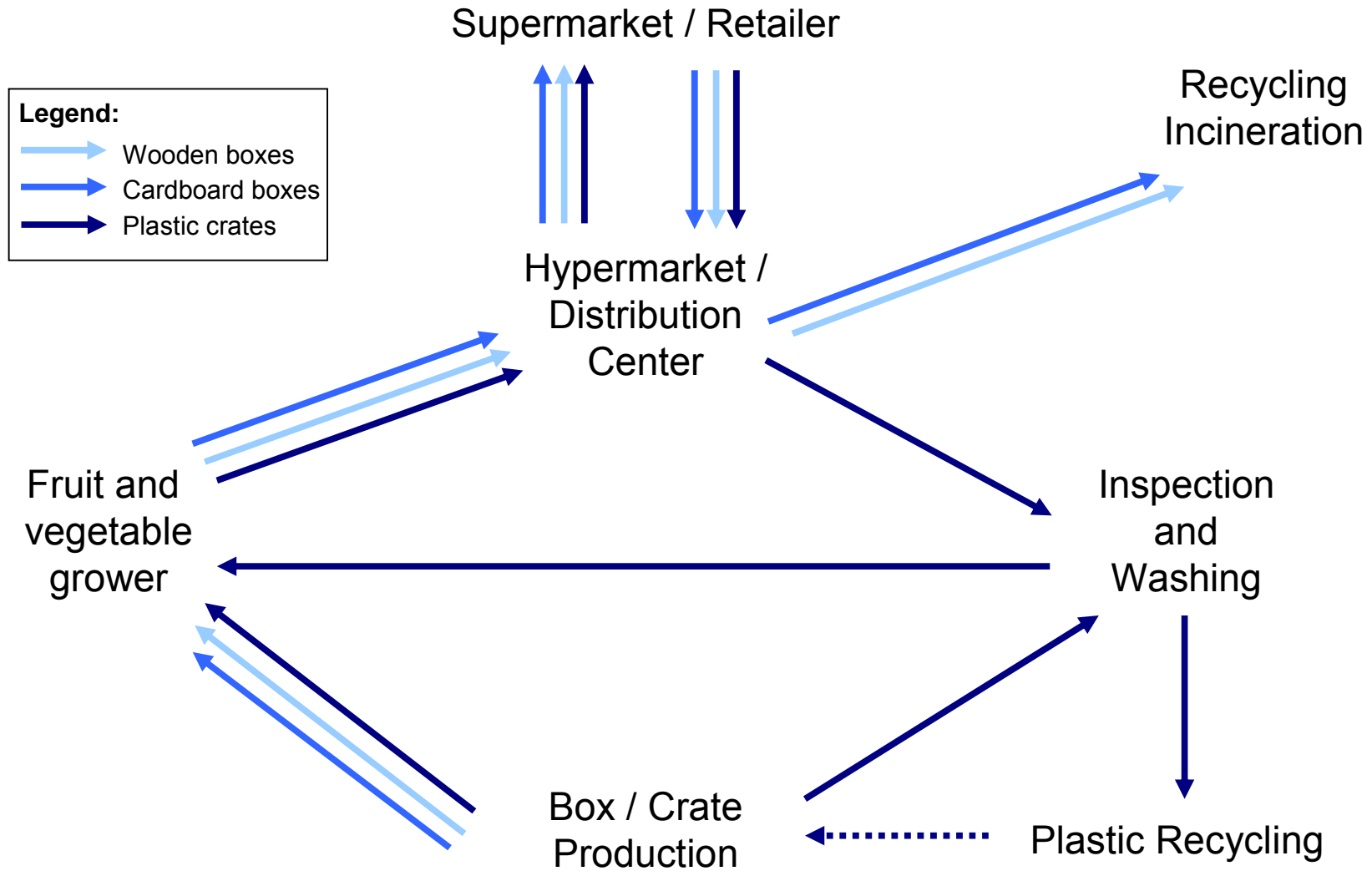



# System and System boundaries

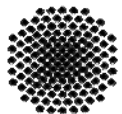
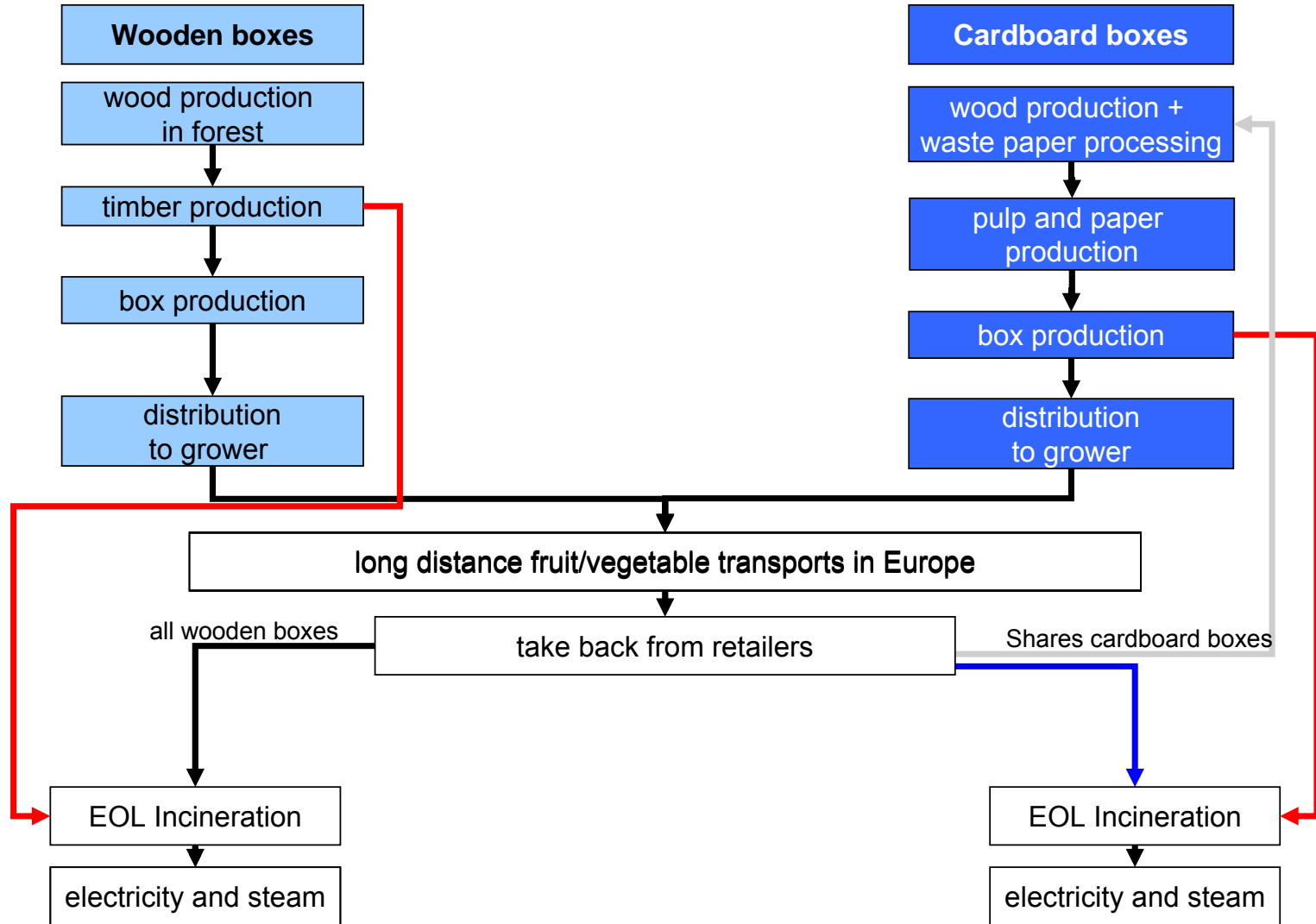

# System and System boundaries

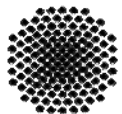
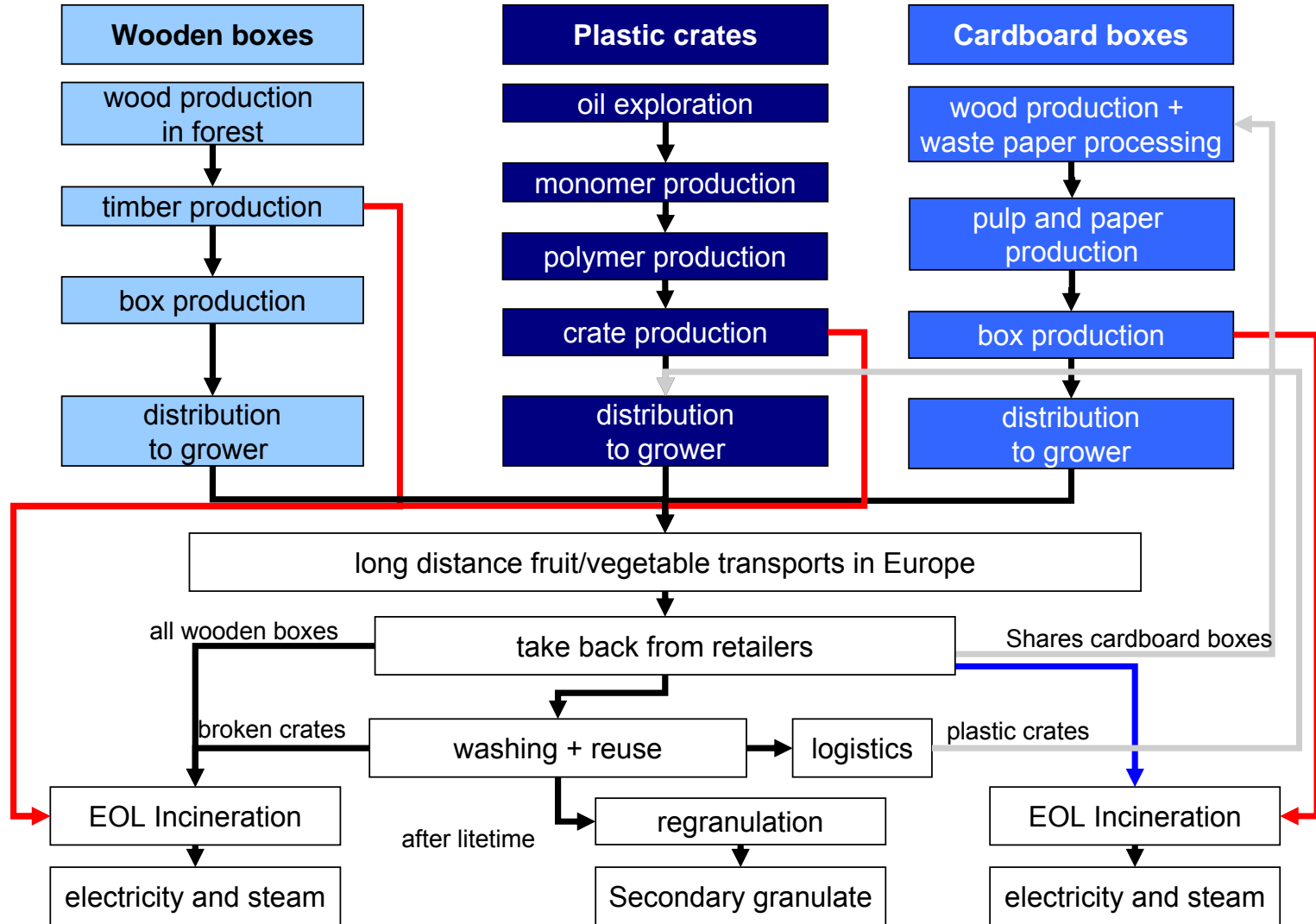

# System and System boundaries

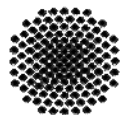
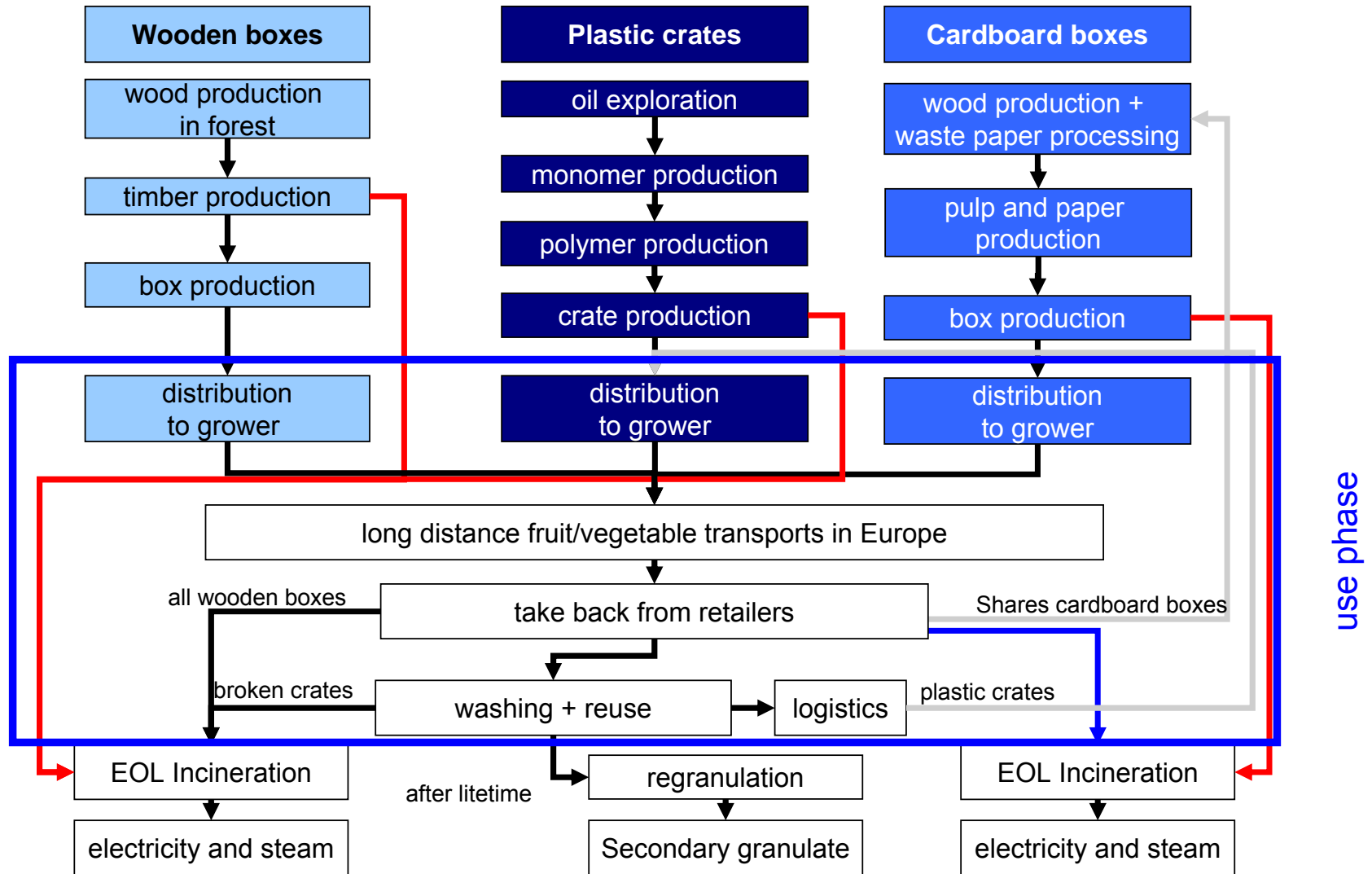

# LCA-Software model (GaBi) use phase plastic crates

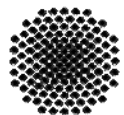
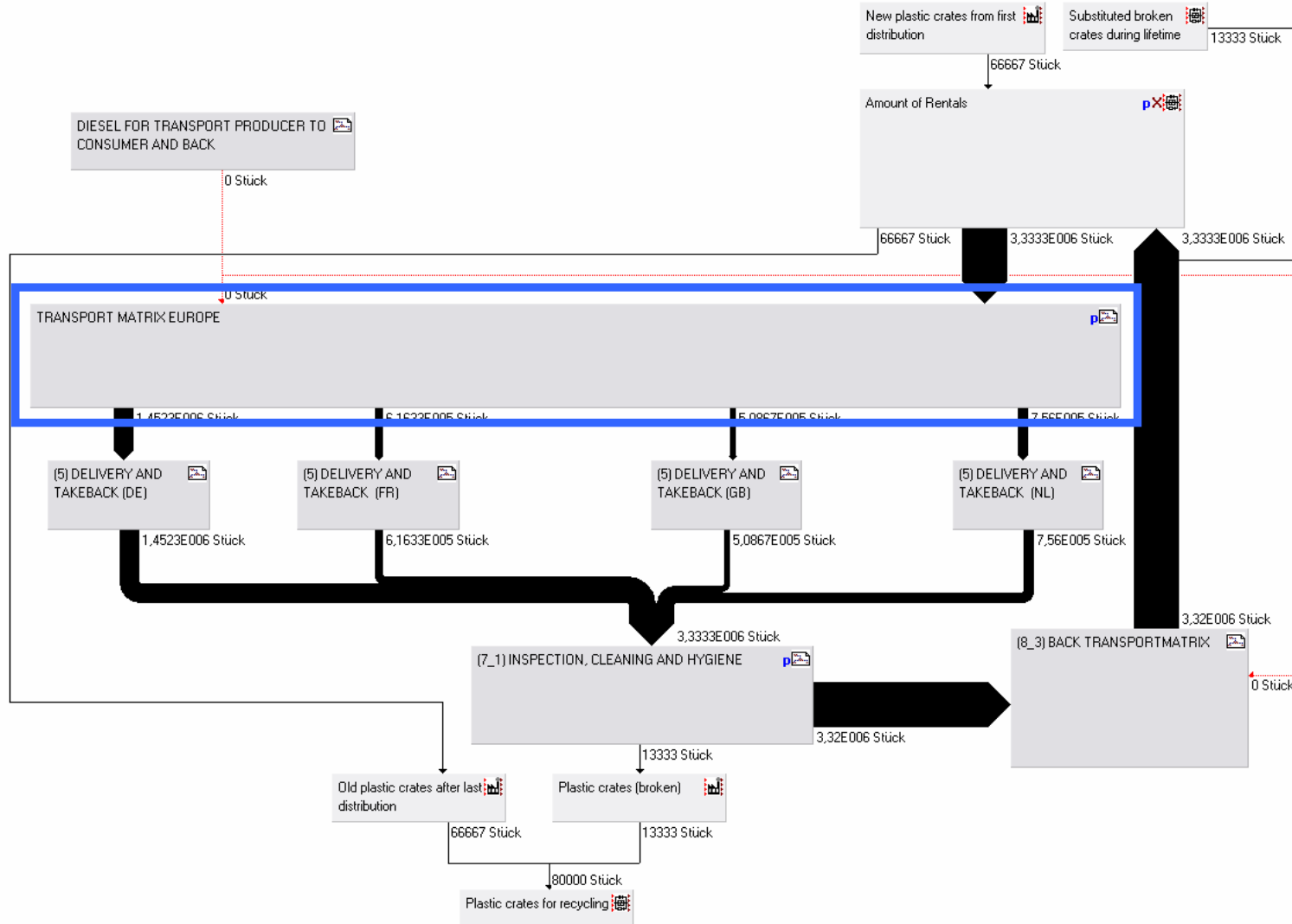

# LCA-Software model (GaBi) Transportation matrix

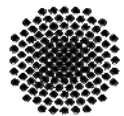
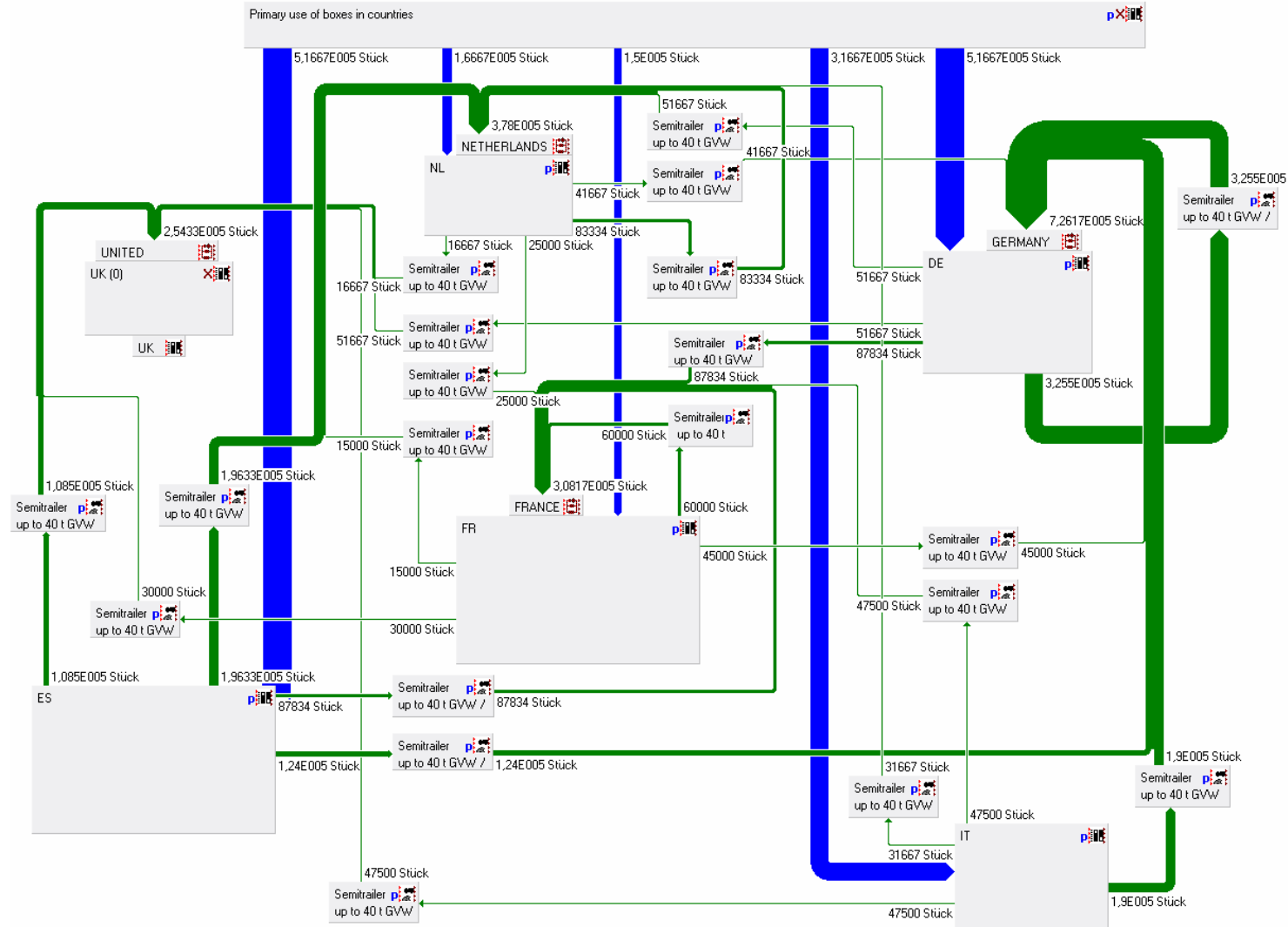

---

## Regarded impact categories

### Environmental impact categories

Environmental indicators and impact categories:

The Primary Energy Demand [MJ]

The Global Warming Potential – “greenhouse effect” [kg CO<sub>2</sub>-Equiv]

The Ozone Depletion Potential – “impact on the ozone layer” [kg R11-Equiv]

The Acidification Potential – contribution to “acid rain” [kg SO<sub>2</sub>-Equiv]

The Eutrophication Potential – contribution to “over-fertilisation” [kg PO<sub>4</sub>-Equiv]

The Photochemical Ozone Creation Potential – contribution to “summer smog” [kg C<sub>2</sub>H<sub>4</sub>-Equiv]

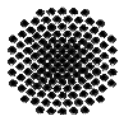

---

# Regarded impact categories

## Economic and social indicators

### Economic Indicators:

The Life Cycle Costs [€]

### Social Indicators:

The total time of work [sec]

The total time of women work [sec]

The differentiation of the working time into qualification levels

The number of lethal and non-lethal accidents

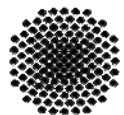

# Selected results

## Environmental impacts: related to the biggest contributor

variation due to potential optimization in cardboard box design

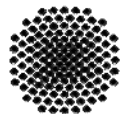
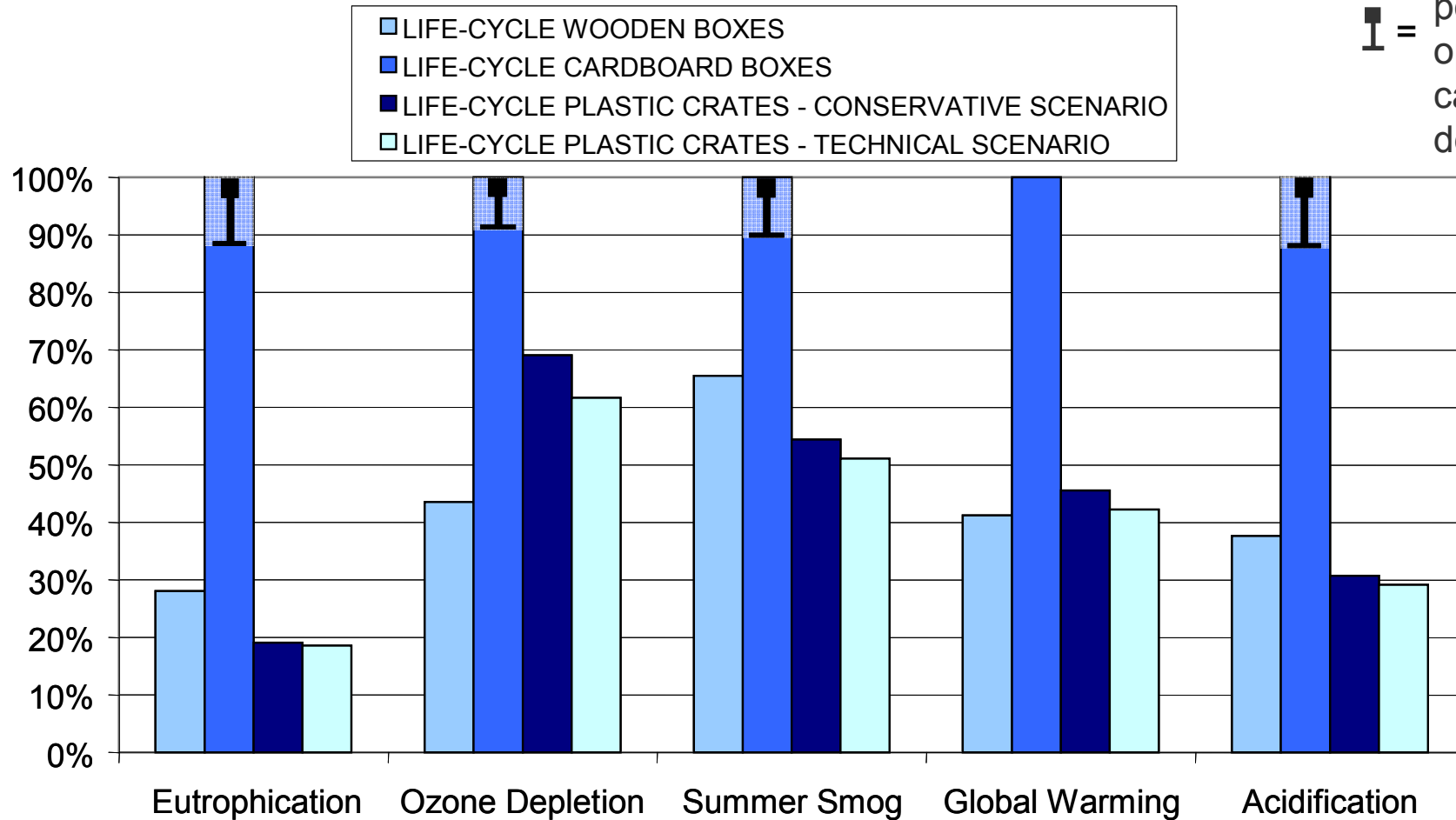

# Selected results

## Life Cycle Costs: conservative and technical scenario

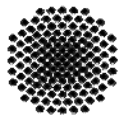
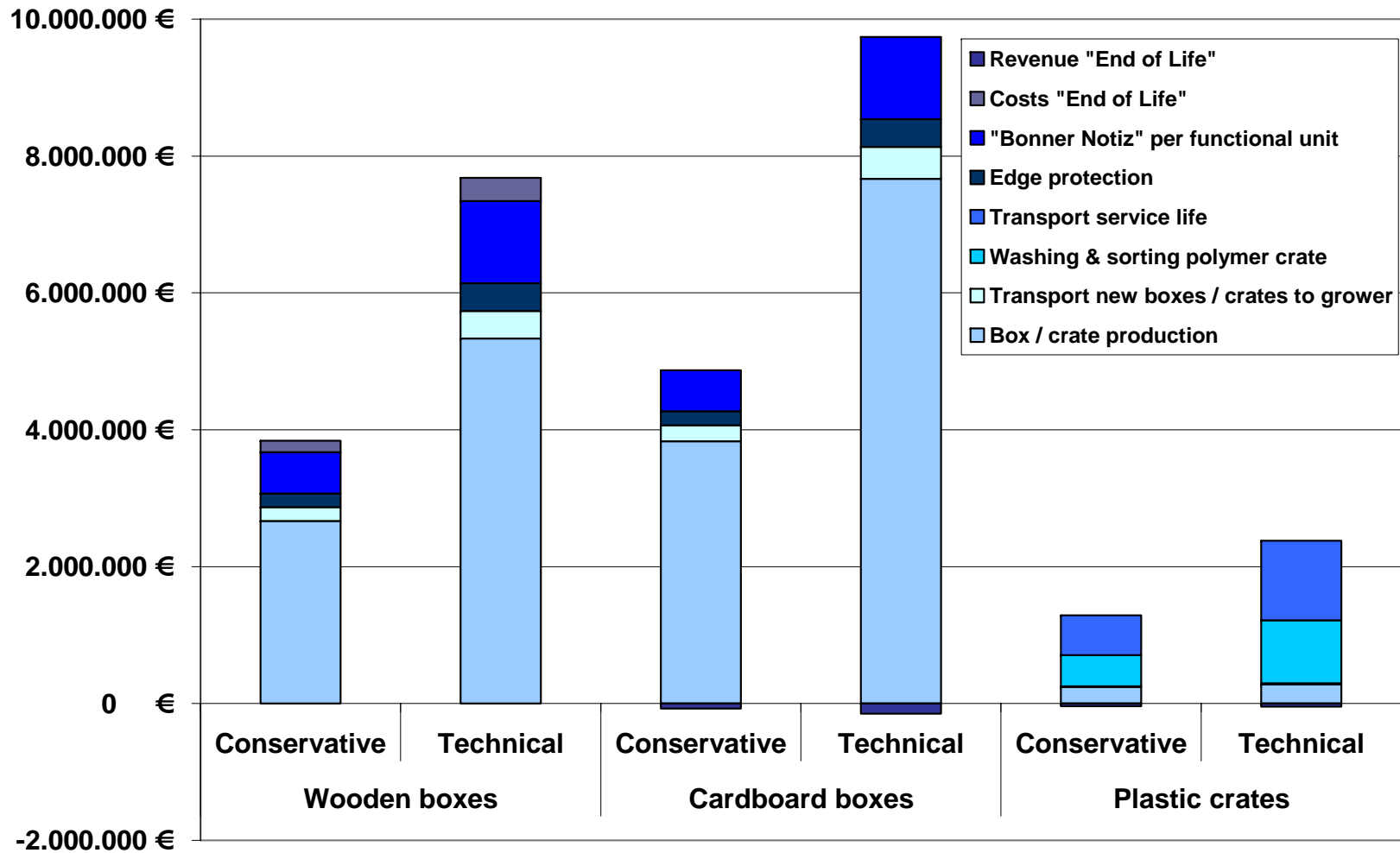

# Selected Results

## Social aspects: Human labour per box/crate

[sec/crate]

Box/crate production - total work and women share

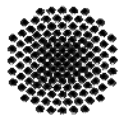
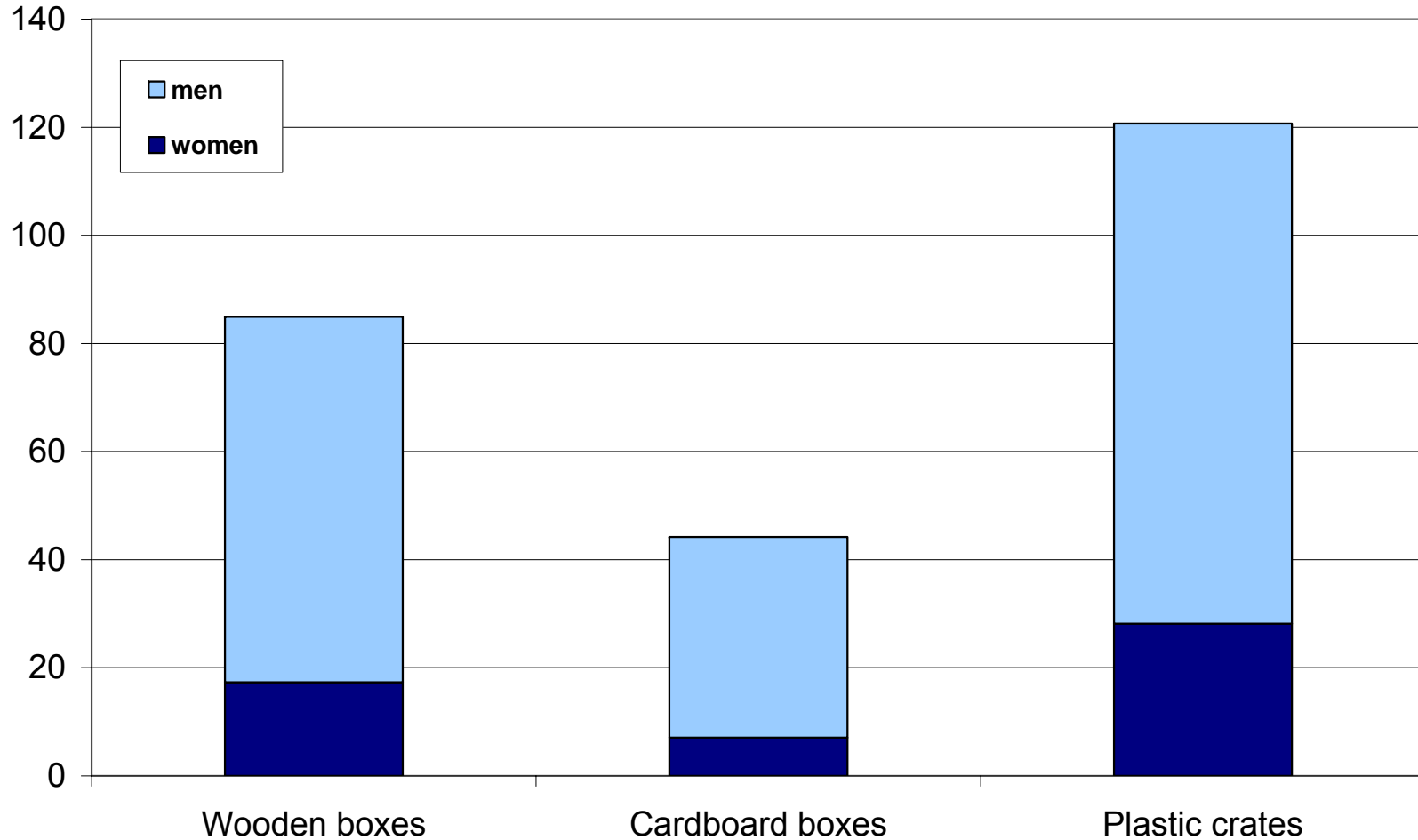

## Selected Results

### Social aspects: working hours for production and operation (FU)

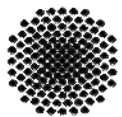
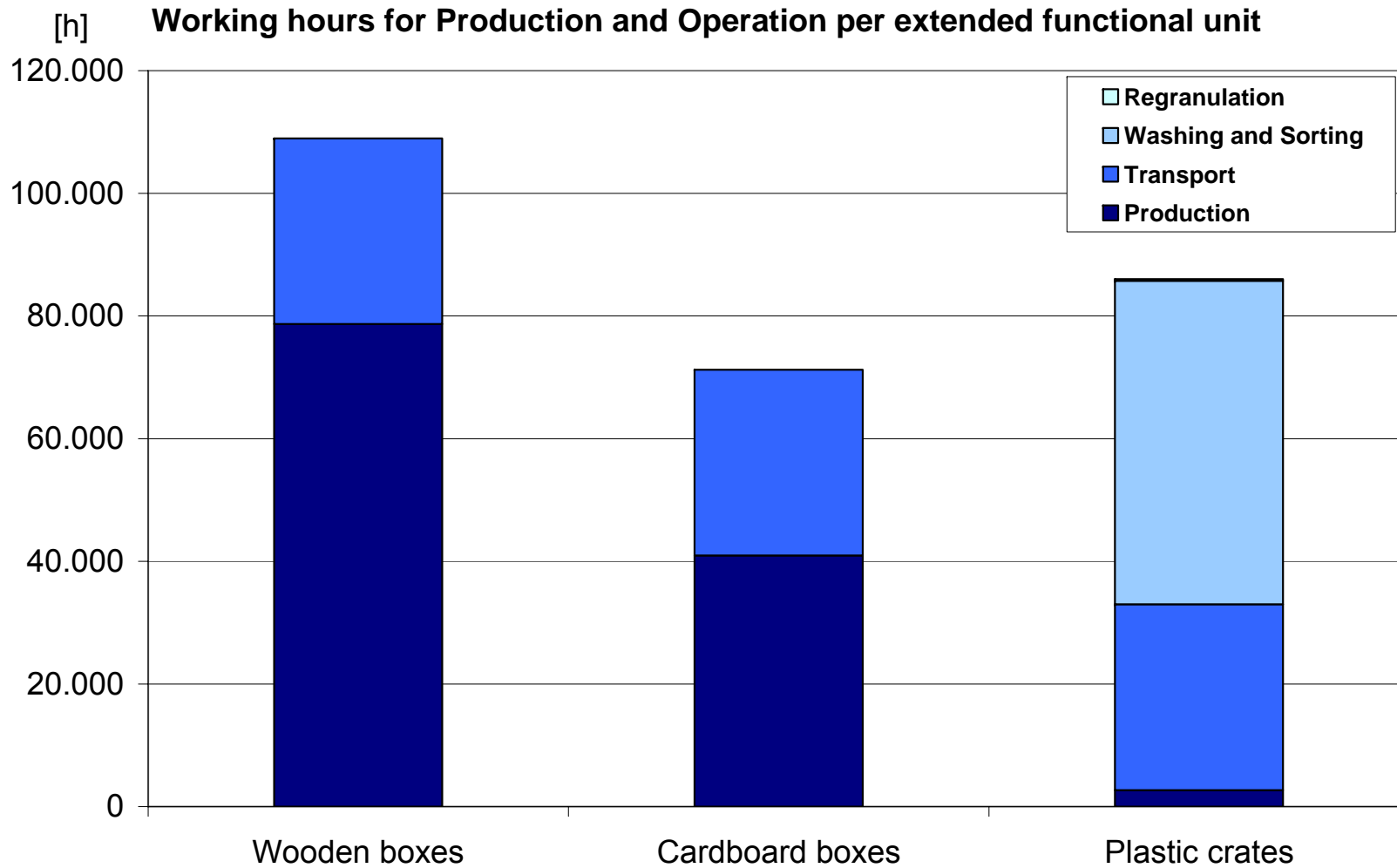

# Conclusions

- ▶ The environmental, economic and social impacts of three different packaging systems for fruit and vegetable transport in Europe: wooden boxes, cardboard boxes and plastic crates were analyzed within the same system boundaries.
- ▶ For each system the main contributors and their influence to the environmental impacts were identified and quantified
- ▶ Parameter variations has been done to quantify the influence of the most crucial parameters within each system
- ▶ Knowledge about economic and social behavior of three different packaging systems within a life cycle view was gained
- ▶ The study was conducted in accordance with ISO 14040 and 14044 and was undertaken a Critical Review according ISO 14040/44 by
  - Angeline de Beaufort-Langeveld  
Expertise on paper and cardboard;
  - Dipl.-Ing. Sebastian Rüter and Prof. Dr. Arno Frühwald, University of Hamburg  
Expertise on wood
  - Dr.-Ing. Ivo Mersiowsky, Five Winds International  
Expertise on plastics and co-ordination

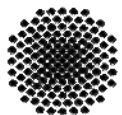

## Additional Information

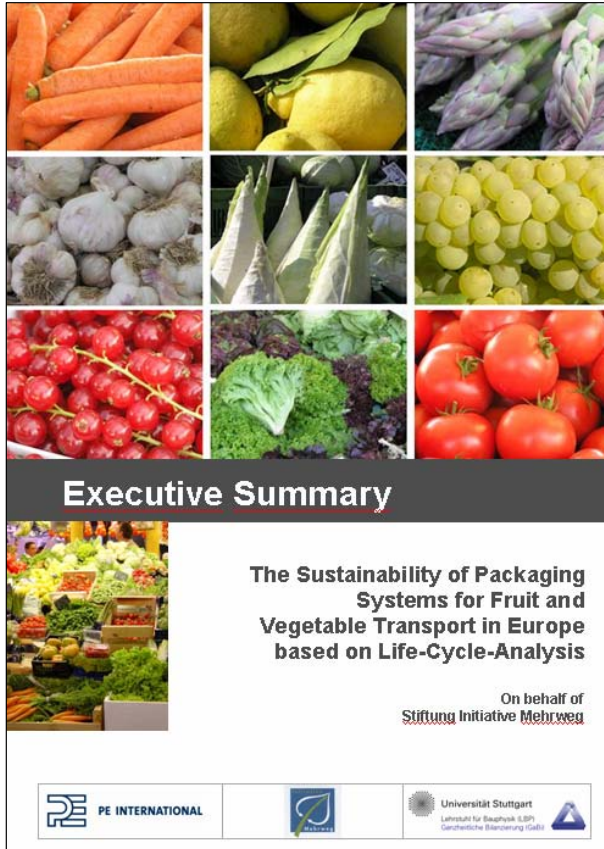

You can find additional information (press kit) under the following address:

german:

[http://www.lbpgabi.uni-stuttgart.de/deutsch/projekte/projekt\\_SIM\\_d.html](http://www.lbpgabi.uni-stuttgart.de/deutsch/projekte/projekt_SIM_d.html)

english:

[http://www.lbpgabi.uni-stuttgart.de/english/projects/projekt\\_SIM\\_e.html](http://www.lbpgabi.uni-stuttgart.de/english/projects/projekt_SIM_e.html)

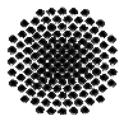

**Universität Stuttgart**

Lehrstuhl für Bauphysik

Life Cycle Engineering



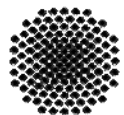
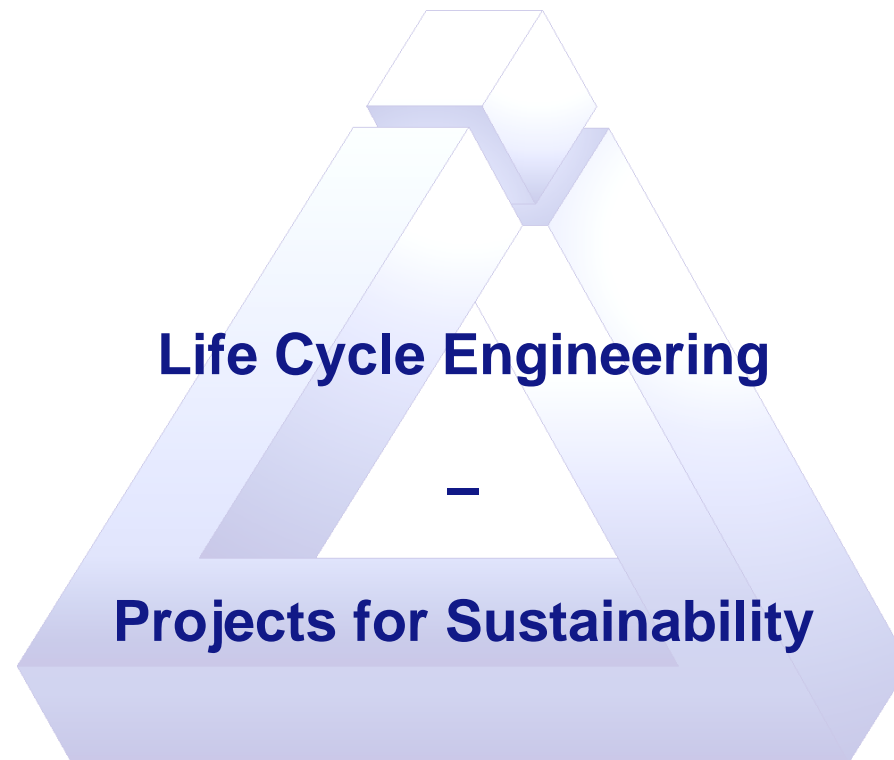

---

# Contact

## Dipl.-Ing. Matthias Fischer

University of Stuttgart  
Chair of Building Physics (LBP)  
Department Life Cycle Engineering (GaBi)

Hauptstrasse 113  
70771 Echterdingen  
Germany

Tel. +49(0)711-489999-21  
Fax +49(0)711-489999-11

E-Mail [matthias.fischer@lbp.uni-stuttgart.de](mailto:matthias.fischer@lbp.uni-stuttgart.de)

<http://www.lbpgabi.uni-stuttgart.de>

